

Clean printing Clear results

SlideMate and SlideMate PLUS slides

- Tab designed for optimal printing on SlideMate AS and SlideMate Pro slide printers
- SlideMate PLUS slide surface has identical properties as Superfrost PLUS
- Adhesion slide surface uses positive charge to attract tissue sections to adhere to the slide
- Generates crisp, clear printing on thermal transfer slide printers



SlideMate Microscope Slides

- Smooth, 3/4 in. tab validated to work with the SlideMate AS and SlideMate Pro slide printers
- Tab is impervious to virtually all common laboratory chemicals and reagents
- Available in adhesion (charged) and non-adhesion (non-charged) formulas
- Slides are made from extra white glass, manufactured to high quality standards
- Slides come pre-cleaned and with finely ground edges
- Dimensions and packaging information
 - 25 x 75 x 1 mm
 - 72 slides/pack,
 - 20 packs/case

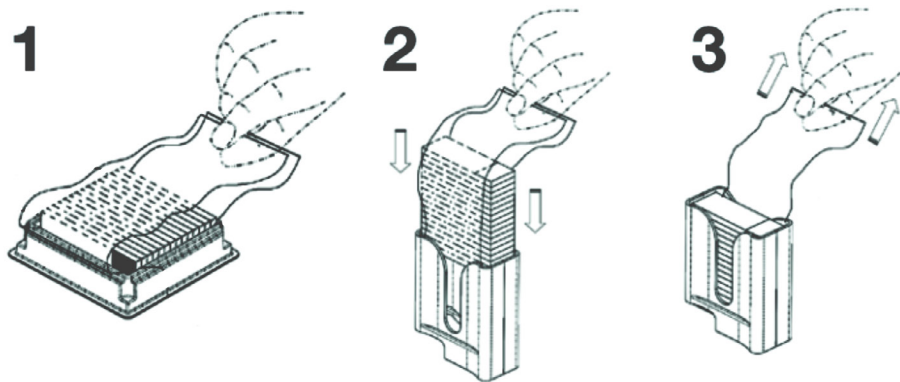

Slides are packed with a special inner wrap to assist with loading into the SlideMate AS and SlideMate Pro hoppers to reduce the possibility of contamination due to handling.

SlideMate PLUS	Cat. Number
White	TT-40418218-PS-W
Blue	TT-50418218-PS-B
Green	TT-60418218-PS-G
Pink	TT-70418218-PS-P
Yellow	TT-80418218-PS-Y

SlideMate	Cat. Number
White	TT-4041-8217W
Blue	TT-50418217-B
Green	TT-60418217-G
Pink	TT-70418217-P
Yellow	TT-80418217-Y

SlideMate Thermal Transfer Slide Printer Family

The SlideMate AS and SlideMate Pro printers are designed to enhance lean workflow with a fully integrated touchscreen and simple software. Built-in barcode scanners read cassette information and import the data to the slide label, printing it directly onto the SlideMate slide.



SlideMate AS Basic Printer	A83900001
SlideMate AS Basic Printing System	A83900002
SlideMate AS On-Demand Printer	A83900004
SlideMate AS On-Demand Printing System	A83900005
SlideMate Pro Dual Hopper On-Demand Printing System	A83900015

Find out more at [epredia.com](https://www.epredia.com)